

DISOMAT® Satus Weighing Transmitter



- Digital Weighing Transmitter
 - Level Control
 - Single-Component Feed Control System
 - System-Compatible with Fieldbus, Serial Interface, Analog Output and Binary Inputs and Outputs
 - Ethernet Connection
 - Comfortable commissioning with the DISOPLAN Program
 - Four 230 V Relay Outputs
 - Three Binary Inputs
 - Optional Weight Display
- Model Designed for Connecting Scales in Hazardous Areas**

Application

The DISOMAT® Satus weighing transmitter is a reasonably priced solution for many basic weighing tasks.

Its fieldbus, serial interface and analog output make it suitable for scales not operated on-site which are connected to higher-order electronic data processing and PLC systems. The optional display also allows on-site monitoring of weight values.

Typical Applications for the DISOMAT® Satus are:

- Weight sensor for weight control and bin level measurement. Serial or analog transmission of data to an electronic data processing or PLC system
- Monitoring of containers' fill levels, indicating MIN and MAX values via parallel contacts
- Single-component feed process (GIW or LIW operation).

Design

The VSE 20900 basic board comprises the following functions:

- Measuring circuit with A/D conversion
- 4 relay outputs safety separated
- 3 binary inputs, galvanically free
- 1 analog output
- 3 serial interfaces
- Ethernet connection (10/100Mbaud)
- Extension connector for fieldbus module (Profibus / DeviceNet / Ethernet IP)

The following functions can be executed using expansion cards:

- PROFIBUS coupling
- DeviceNet coupling
- Display, 3 1/2 digits, 10 mm digit height, for weight monitoring.
- 3 push-buttons for controlling scales functions

The basic board is slotted into a 19" sub-rack as a plug-in board. The device is powered either by 24 VDC or by optional 115 / 230 VAC power supply modules.

Weighing sensors and display devices in category 2G (zone 1) are connected using the optional barrier sets. The barrier sets are inserted directly into the 19" slots.

Alternatively, the DISOMAT® Satus may come fitted in a field housing. This version also comes with the option of 24V power supply and integrated power supply unit.

The field housing comes in designs suitable for direct on-site assembly in potentially hazardous areas of the category 2D / 3G.

Communication

With up to three serial interfaces, the DISOMAT® Satus is fully equipped to exchange data with its environment.

For example,

- Configuration
- Serial display
- Data Processing

may be connected in parallel. Two of the interfaces are RS-232 interfaces. The third (RS-485, 2/4-wired) is specially suited to communication within the bus and over longer distances.

In control systems the Ethernet connector (10/100 MBaud) is operated using the MODBUS/TCP protocol.

Alternatively, HTML pages stored in the device may be called up using a standard web browser. The device can also be configured via the Ethernet interface.

Furthermore, the standard fieldbus systems

- Profibus DP-V0 and
- DeviceNet
- Ethernet IP

can be connected via matching optional coupling modules.

Parallel Signal Exchange

The DISOMAT® Satus is equipped with the following inputs and outputs for control tasks:

- Three 24 V optical couplers. The inputs can be used to control the feed process (Start / Stop / Abort) or to use the basic scales functions (set / clear Tare / zero setting).
- Four relay outputs for limit value monitoring, status messages or for controlling the filling/discharge operation, naturally also suitable for 230 VAC.

It is also equipped with a 12 Bit analog output that can e.g. transmit weight or material flow to a PLC or display. The analog output can also be used for direct control of suitable feed units.

Engineering

In spite of its reasonable price, the DISOMAT® Satus has enormous processing power. The 32-bit ARM controller has sufficient power reserves for fast weighing-processes, simultaneous operation of the various interfaces and for future applications.

Configuration

The PC program DISOPLAN is used to configure the DISOMAT® Satus. It allows you to

- set all device parameters
- adjust the device
- record and display weight curves
- readout the complete device configuration (backup)
- restore stored data in a DISOMAT (restore). This allows e.g. a replacement device to be prepared at short notice.

Feed Functions

The DISOMAT® Satus feed functions can be adjusted within a wide range making them suitable for a multitude of tasks.

Regardless of material, setting the feed primarily involves setting the feed process, i.e.

- Time monitoring (charging / refilling / emptying)
- Optimization
- Multiple feeds (set point > maximum scales-load)
- Automatic / manual functions

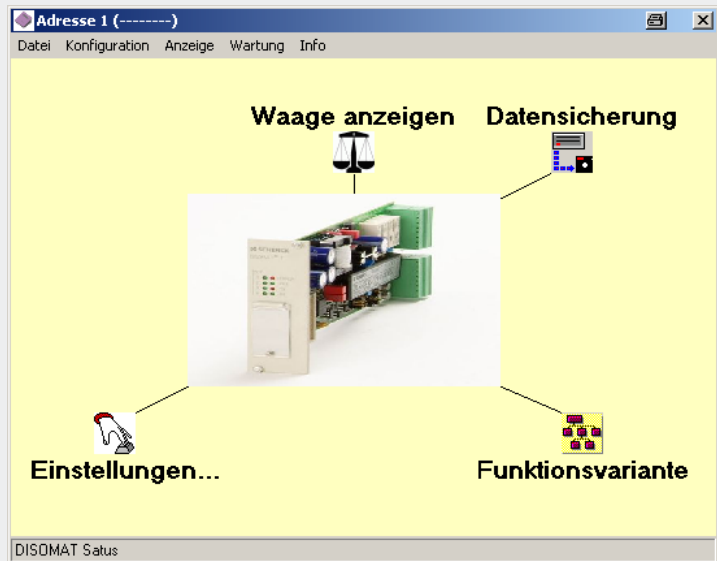

All parameter and calibration data are stored in the device, secured against power failure. The real-time clock will run for at least seven days without a power supply.

Functions

Alongside the basic scales functions such as

- Tare setting/clearing
- Zero setting

the DISOMAT® Satus also has a range of other functionalities.

To use these, one of the device's 'function variants' is activated. This opens an application-specific configuration menu in DISOPLAN in which the device's inputs and outputs can be assigned the corresponding signal.

The following different functions can be activated:

- Weighing transmitter (weighing / monitoring) data transmission / limit-value
- Filling scales / discharge scales (single-component feed process)

Additionally, two product-dependent material datasets may be administered.

These data may contain e.g.

- Pre-contact and main contacts
- Controlling variable in full feed and dribble feed (analog-controlled feed operation)
- Parameters for tolerance check

Multiple-component feeds may also be implemented in conjunction with a higher-order control system that provides the respective component data and set points.

Dongel Concept

The DISOMAT® Satus also makes use of the tried-and-tested 'Intelligent Dongle' concept:

All of the scale's relevant calibration and adjustment data are stored in the dongle. As all the devices are calibrated ex factory, the electronic components can be exchanged at any time in case of a defect. Once the dongle is attached, the scales are configured and adjusted correctly.

Casing
19" VNG 0900 Sub-Rack
 (Fig.1)

Suitable for control cubicles which are accessible from the rear or which have a pivoting frame.
 The VNG 0900 has room for 10 main cards.
 Each of the following require one slot:

- VSE 20900
 DISOMAT® Satus circuit board
- VXB 20900/20910
 Explosion protective circuit
- VNT 209xx
 power supply unit for 115/230 VAC
- blank front panel
- The weighing transmitter model with display requires **two** slots

The optional bus cards require no additional slots.

Protection class at the frontside: IP 20
 Approx. weight (fitted): 10 kg

VFG Field Housing
 (Fig.2)

A VSE 20900 is built-in for on-site installation.
 Cards such as:

- DeviceNet expansion card
- Profibus expansion card
- Ethernet IP

may also be fitted.

ATEX variants are available for use in:

- Category 3G (zone 2), 24 VDC only
- Category 2D (zones 21,22)

Material: Polyester
 Protection class: IP 65
 Approx. weight: 3-4 kg

Dimensions:

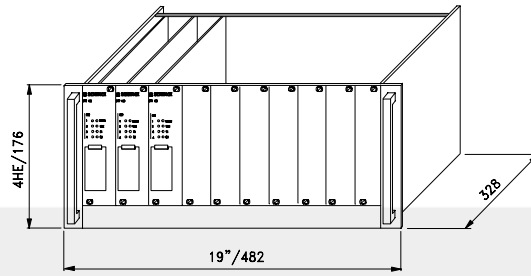

Fig.1
 19" VNG 0900 Sub-Rack

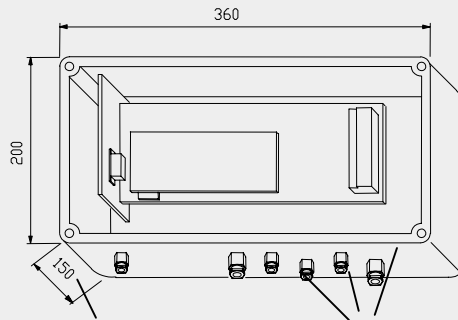

Fig.2
 VFG Field Housing

Height incl. Top Cover

Cable Entries
 2 x M20, 5 x M16, 1 x M25

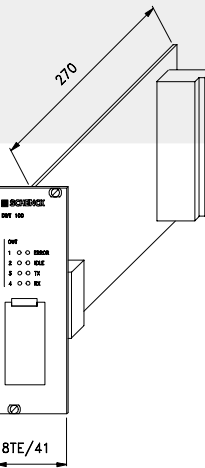

Fig.3
 VSE 20900 Weighing Transmitter
 The following components have equal dimensions:
 - explosion protective circuit VXB 209xx
 - power supply unit VNT 209xx

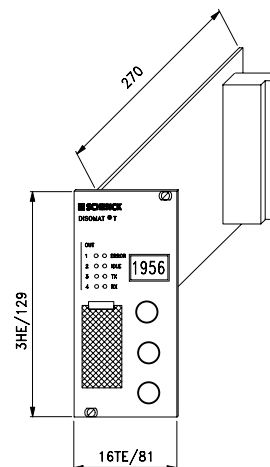

Fig.4:
 VSE 20910
 Weighing Transmitter

The optional version with 3,5 digits display (digit height 10 mm), and three function buttons - occupies two slots in the plug-in board.

Technical Data:

The supply voltage for 19" VFE 20900 unit	18-36 VDC
The supply voltage for VFG 20900 / 20910 field unit	18-36 VDC / 115/230 VAC
Power consumption	Max. 10 VA
Temperature range	Service temperature: -30 to +60°C Storage temperature: -40 to +80 °C
Measuring channels	1
Load cell supply	5 V alternating voltage supply
Input signal	0 to 15 mV
Sensitivity	0.7 µV/d
Accuracy	Linearity error: < 0,05 ‰ Zero setting stability, TK ₀ : < 1,0 µV / 10k corresponds: < 0,07 ‰ / 10k related to max. Input signal Zero setting stability TK _c : < 0,1 ‰ / 10k Compound error, F _{comb} : < 0,2 ‰ / 10k
unit	kg, g, t, lb, N, kN
Increment value	1, 2 and 5 etc. adjustable from 0.01-5,000
Taring	To 100% of the weighing range
Load cell impedance:	Min.47 Ω (corresponds to 8 x 350 Ω - load cell or > 20 Ring Torsion load cells à 4,000 Ω)
Date/Time	Real-time clock (RTC), Power-failure backup min. 7 days
Casing (VSE model)	19" cassette, 3HE, 8TE
Housing (VFE Type)	Plastic protection class IP 65 suitable for wall-mounting
Binary inputs	3 x optical-couplers, 18 - 36 VDC, 5 mA typically Fourth input available for optional use
Binary outputs	4 x relays, 230 VAC, 60 W max.
Analog output	1 x 0(4) - 20mA, 12 Bit, max. load 500 Ω, maximum permitted external load reduced to 250 Ω if optional DISOMAT® Satus display is used. Use of VXB safety barriers also reduces permitted impedance of analog output.
Serial interfaces:	3 interfaces for electronic data processing or second display Interfaces 1 and 2: RS 232 Interface 3: 485, 2/4 wired; Max. baud rate: 38,400
Data processing protocols	Siemens 3964R S5 (RK512) Schcnck standard protocols DDP8672 Schcnck poll protocols DDP8785 MODBUS
Secondary display protocols:	DTA DDP 8861 DDP 8850
Ethernet interface	10/100 MBaud, on-board MODBUS/TCP protocol

Options	
Fieldbus	Profibus DP-V0 DeviceNet Ethernet IP
Power supply unit	- VNT 20901 for 230 V~, -15% +10% One power supply unit supplies up to 9 VSE 20900 main boards with fieldbus option
Explosion protection	Explosion protective circuit VXB 209xx for connection of electrical equipment in zone 1 (ATEX II 2G) card incl. front plate in same dimensions as VSE 20900 main boards Explosion protection class "intrinsically safe" for: - load cell connection - serial interface for second display - analog output for second display - binary input for two contacts Warning: If connecting the analog output in the hazardous area, the maximum external load through the barrier's series resistance is reduced by approx. 300Ω.
Display	Displays for analog output and serial interface, fully integrable into device. WARNING: The use of the analog displays reduces the permitted external load of the analog output by 250Ω. This option may not be combined with the connection of the analog output in the ex-area.
Configuration software	DISOPLAN VPL 20430 for Windows NT / 2000

Equipment Supplied:

V052188.B01	DISOMAT® SATUS VSE 20900 circuit board incl. front plate
V052188.B02	DISOMAT® SATUS VSE 20901 circuit board incl. front plate; with mounted PROFIBUS option
V053903.B01	DISOMAT® SATUS VSE 20910 circuit board incl. front plate, with integrated LED weight display
V053921.B01	DISOMAT® SATUS in the VFG 20900 field casing for 24 VDC supply
V053921.B02	DISOMAT® SATUS in VFG 20901 field casing for 24 VDC supply; with mounted PROFIBUS option
V053922.B01	DISOMAT® SATUS in VFG 20910 field casing with transformer for 115/230 VAC supply
V053922.B02	DISOMAT® SATUS in VFG 20911 field casing with transformer for 115/230 VAC supply; with mounted PROFIBUS option
V055346.B01	VNG 0900 19" rack
V053978.B01	Power supply unit VNT 20901 230 V AC, for up to 9 VSE 209xx
V068489.B01	VXB 20901 safety barriers for RTN/RTB/VBB/PWS load cells in potentially hazardous area of ATEX category 2G
V068493.B01	VXB 20911 safety barrier for RTK/DMA weigh cells
V053917.B02	Profibus installation set for DISOMAT® SATUS
V053918.B02	DeviceNet Satus installation set
V029764.B01	DISOPLAN VPL 20430 configuration software